

**NEWTON COMMUNITY DEVELOPMENT BLOCK GRANT
Newton Housing and Community Development Program
Planning and Development Department
APPLICATION FOR FY11-FY15 CDBG ACCESS FUNDING**

Application must be completed electronically and submitted with original signature by 12 p.m. Friday December 18th, 2009

Kathleen Cahill, Senior Planner
Department of Planning and Development
1000 Commonwealth Avenue Newton, MA 02459-1400
kcahill@newtonma.gov (617) 796-1125

Before completing this application please read the document entitled "Important Information on CDBG Access funding."

SECTION 1. PROJECT CONTACTS

Name(s): Carol Schein

Organization/City Department: Parks and Recreation Dept.

Mailing address: 70 Crescent St., Newton, MA 02466

Phone: 617-796-1507

Email: cschein@newtonma.gov

SECTION 2. PROJECT OVERVIEW

Project title: Burr Park Stair(s) Handrails

Project location (*full street address with zip code*): Burr Park, Park Street, N. Corner 02458

Year CDBG Funds requested: **FY11** FY12 FY13 FY14 FY15

CDBG Access funds requested: \$5000.

Other funds to be used: --

Total project cost: \$5000.

Project Summary (*the project summary should: describe how the project addresses the removal of barriers to access, specify the company, contractor, non-profit, or City department that will complete design work, construction, installation and/or provide materials and explain who will be responsible for maintaining the project*). Note: bids in the amount of \$5,000 and over must go through a public bidding process. Projects over \$2,000 are subject to Davis-Bacon Act federally prevailing wages.

P&R has been informed by the Planning Dept. that the existing handrails that were installed years ago at the stairs at Arlington Street and the two sets of stairs at Park Street are non-compliant and need to be replaced with ones that are compliant.

P&R has been told by the Planning Dept. that the cost to replace all the rails is estimated at \$5000.

SECTION 3. PROJECT TIMELINE

Use the table below to provide a project timeline (including proposed start, completion dates, and any other steps):

Date/Season		Description of Step
Start	Fall 2010	Remove/install handrails
Completion	Fall 2010	Project complete

If the fiscal year CDBG assistance awarded is different than the year requested, will the department/organization still be able to implement the project?

Yes.

SECTION 4. PROJECT ACCOMPLISHMENTS

What is the total estimated number of persons to be served by this project?

There are 83,829 residents in the City that could potentially be served by this project.

Of that total, what is the total estimated number of elderly persons or adults with severe disabilities that will be served by this project?

The 2000 Census reported 3,394 Newton residents with physical disabilities; the 2005-2007 Census estimates there will be 3,967 residents with disabilities.

SECTION 5. PROJECT BUDGET

Item	CDBG	Other Funds	Source of Other Funds	Total
<i>Remove/replace handrail(s)</i>	\$5000			<i>\$5000.</i>
Total CDBG Request	\$5000			
Total Other Funds				
Grand Total				\$5000

If any of the "other funds" listed in the above budget have not yet been obligated to the project explain what needs to take place for this to happen?

n/a

Has the applicant explored other (internal and/or external) funding sources for this project? If yes, please indicate why CDBG funds would be a better source of funding?

This is an appropriate project for CDBG as CDBG funds covered the cost of the original handrails.

SECTION 6. PLANS AND PHOTOGRAPHS

Applications for construction projects must be accompanied by an architect's or engineer's plan – contact staff for more detailed information. The submission of photographs is also encouraged.

SECTION 7. PROJECT MANAGER

Name: Carol Schein

Title: Open Space Coordinator

Telephone: 617-796-1507

Email: cschein@newtonma.gov

I certify that all information submitted in this application is complete, true, correct, and represents the true intended usage of the funds for which the application is being submitted:

Signature

Date

ATTACHMENT I: APPLICABLE REGULATIONS

4.9.4* Handrails. Stairways shall have handrails at both sides of all stairs. Handrails shall comply with [4.26](#) and shall have the following features:

- (1) Handrails shall be continuous along both sides of stairs. The inside handrail on switchback or dogleg stairs shall always be continuous (see [Fig. 19\(a\)](#) and [\(b\)](#)).
- (2) If handrails are not continuous, they shall extend at least 12 in (305 mm) beyond the top riser and at least 12 in (305 mm) plus the width of one tread beyond the bottom riser. At the top, the extension shall be parallel with the floor or ground surface. At the bottom, the handrail shall continue to slope for a distance of the width of one tread from the bottom riser; the remainder of the extension shall be horizontal (see [Fig. 19\(c\)](#) and [\(d\)](#)). Handrail extensions shall comply with [4.4](#).
- (3) The clear space between handrails and wall shall be 1-1/2 in (38 mm).
- (4) Gripping surfaces shall be uninterrupted by newel posts, other construction elements, or obstructions.
- (5) Top of handrail gripping surface shall be mounted between 34 in and 38 in (865 mm and 965 mm) above stair nosings.
- (6) Ends of handrails shall be either rounded or returned smoothly to floor, wall or post.
- (7) Handrails shall not rotate within their fittings. [Appendix Note](#)

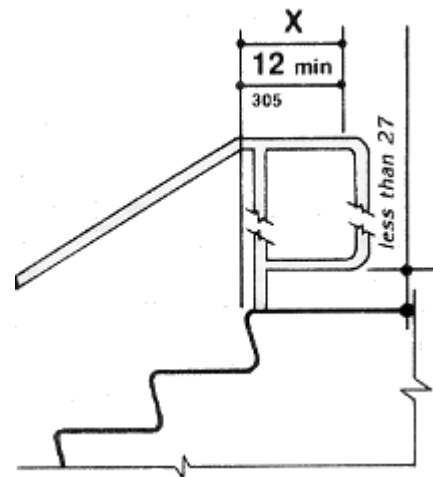
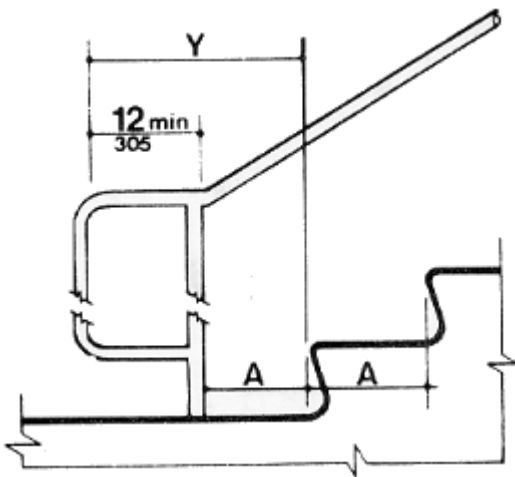

ATTACHMENT II: BURR PARK PHOTOGRAPHS



